

**INSTRUCTIONS AND PARTS LIST
FOR SETTING UP AND OPERATING**

MILLERS FALLS
"Langdon Acme" Mitre Box
"Langdon" Mitre Box
"All Steel" Mitre Box



Mark of Superiority

— **IMPORTANT** —

Read This Booklet Carefully!

You have purchased a valuable piece of equipment. With the proper care and use it will give you many years of trouble-free and dependable service. **SPEND THE 20 MINUTES REQUIRED TO READ THESE INSTRUCTIONS.** Learn how to assemble it and how to operate it properly before you saw your first piece of wood.

This booklet will assure your being able to obtain proper parts service at all times. We suggest that you keep it where it will be available for future reference.

Be sure you understand the conditions of the Guarantee on the inside of this cover.

MILLERS FALLS COMPANY
Greenfield, Massachusetts, U.S.A.

PRICE 50¢

CLAIMS

No claims for inaccuracy or repair can be allowed if this Mitre Box has been abused or tampered with, or has been operated contrary to this instruction booklet. Should a Box be returned for supposed inaccuracy, the Saw used with it and a sample of work (minimum length 12 inches) with inaccurate cut must be included.

GUARANTEE

Mitre Box with Saw

A Mitre Box purchased WITH SAW has been thoroughly tested and inspected both for workmanship and accuracy at the factory. It is guaranteed to give and continue to give accurate cuts only if operated per instructions in this booklet. The Mitre Box is NOT guaranteed to give accurate cuts on warped, crooked, or defective lumber.

GUARANTEE

Mitre Box without Saw

A Mitre Box, purchased WITHOUT SAW has been thoroughly tested and inspected both for workmanship and accuracy with a factory Master Saw. No two Saws will cut identically even though new, and for this reason a Mitre Box purchased without Saw cannot be guaranteed. For Maximum accuracy, the Saw should be fitted at the factory.

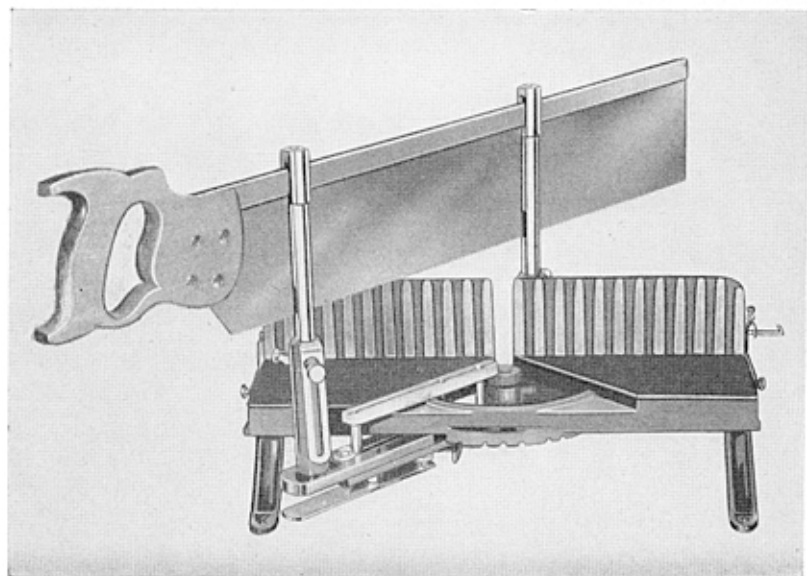

Figure 1

"LANGDON ACME" MITRE BOX

With Saw	Without Saw
No. 72C — 24 x 4 Saw	No. 1071C — 4 Inch
No. 73C — 26 x 4 Saw	
No. 74C — 28 x 5 Saw	No. 1074C — 5 Inch
No. 75C — 30 x 5 Saw	

The "Langdon Acme" Mitre Box (Fig. 1) is the finest machine made for cutting Angles in wood. It has a rugged one piece cast iron Bed and Backs. Saw Guides, Swinging Lever and Legs are of steel. Three "Oilite" Bronze Bearings are provided in each Guide for smooth and easier Saw travel.

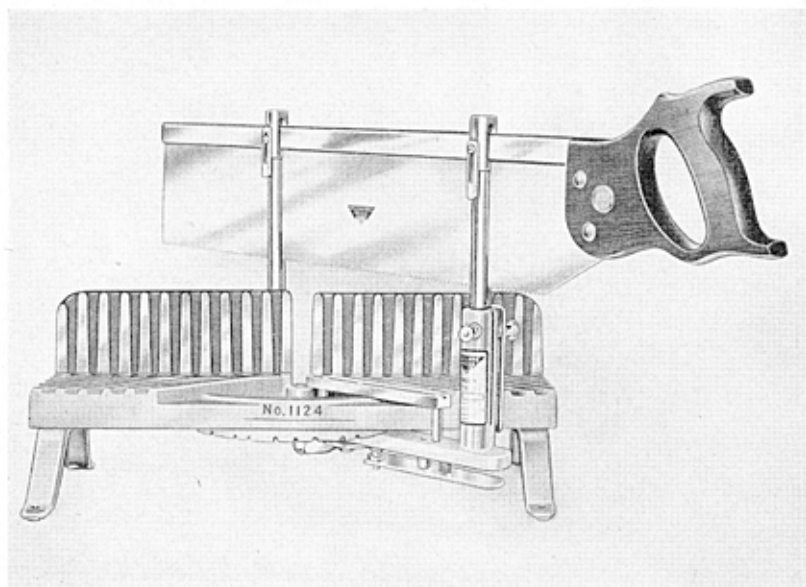

Figure 2

"LANGDON" MITRE BOX

With Saw

No. 1124 - 24 x 4 Saw

Without Saw

No. 1120

The "Langdon" Mitre Box (Fig. 2) is a fine machine for cutting angles in wood. It has a rugged one piece cast iron Bed and Backs. Saw Guide, Swinging Lever, and Legs are of Steel. Adjustable Swinging Lever, End Brackets, Length Gage and graduated Quadrant are not provided on this Mitre Box, consequently operations as shown on pages 10, 12, 13, 14, and 15 in this instruction booklet cannot be performed.

The capacity of this Mitre Box is $8\frac{3}{4}$ inches at Right Angles and a full 6 inches at either Mitre.

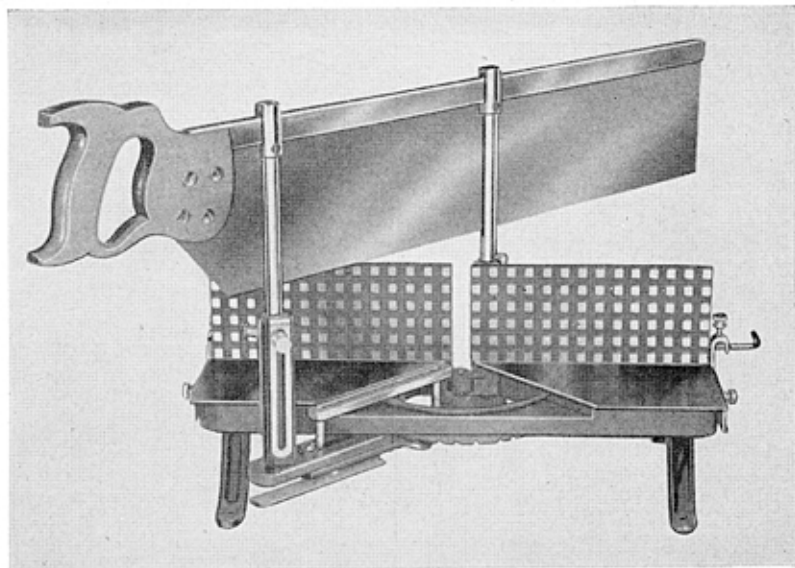

Figure 3

"ALL STEEL" MITRE BOX

With Saw	Without Saw
No. 1244C — 24 x 4 Saw	No. 1002C — 4 Inch
No. 1264C — 26 x 4 Saw	
No. 1285C — 28 x 5 Saw	No. 1003C — 5 Inch
No. 1305C — 30 x 5 Saw	
No. 1306C — 30 x 6 Saw	No. 1004C — 6 Inch

The "All Steel" Mitre Box (Fig. 3) is a fine unbreakable machine for cutting angles in wood. The Bed is arc welded steel truss construction. Rigid Steel Backs are securely fastened to Bed. All other parts are the same as the "LANGDON ACME."

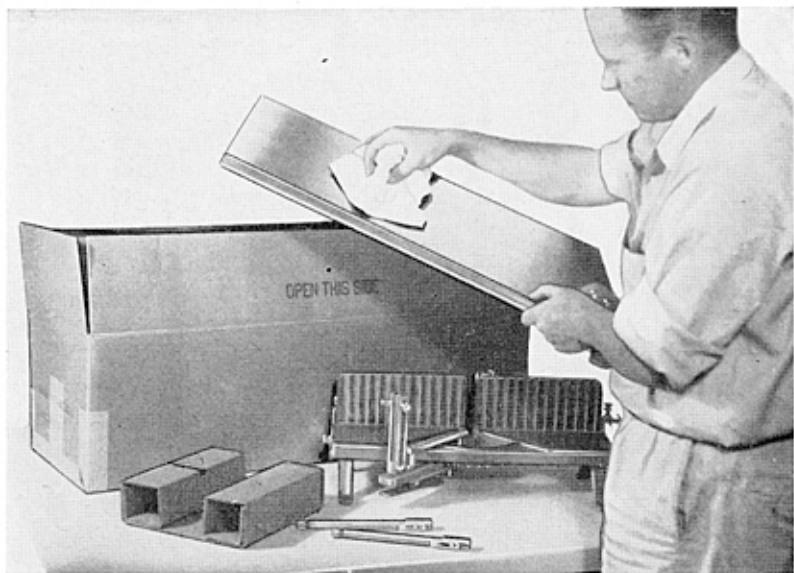

Figure 4

REMOVAL

Carefully remove the fillers, Saw (if furnished) and Mitre Box from the carton. Untie and unwrap Saw Guides which are wired to the front of Bed. With a clean cloth, wipe all oil from Bed, Saw Guides, and Saw (Fig. 4). During use, never oil the Saw Guides or Saw, sawdust will cause them to stick and bind. These parts have been oiled at the factory to prevent rust during shipment and storage. They should be oiled only when Mitre Box is not to be used for a prolonged period.

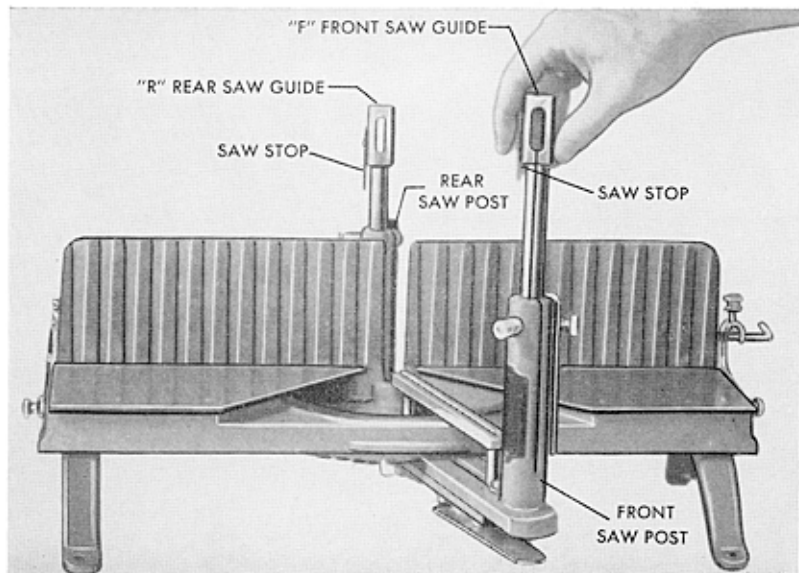

Figure 5

SAW GUIDES

Insert Saw Guides in the proper Saw Posts (Fig. 5). The Saw Guide marked "F" should be inserted in the Front Post also marked "F", nearest the operator. The Saw Guide marked "R" should be inserted in the Rear Post marked "R", farthest from the operator. These Saw Guides are not interchangeable. A different Saw Stop setting is required on each Guide.

Make sure the Bearing Surfaces are clean by working the Guides up and down inside the Posts several times.

Please note that upon proper assembly the adjustable Saw Stops will be on the left side of the Saw Guides.

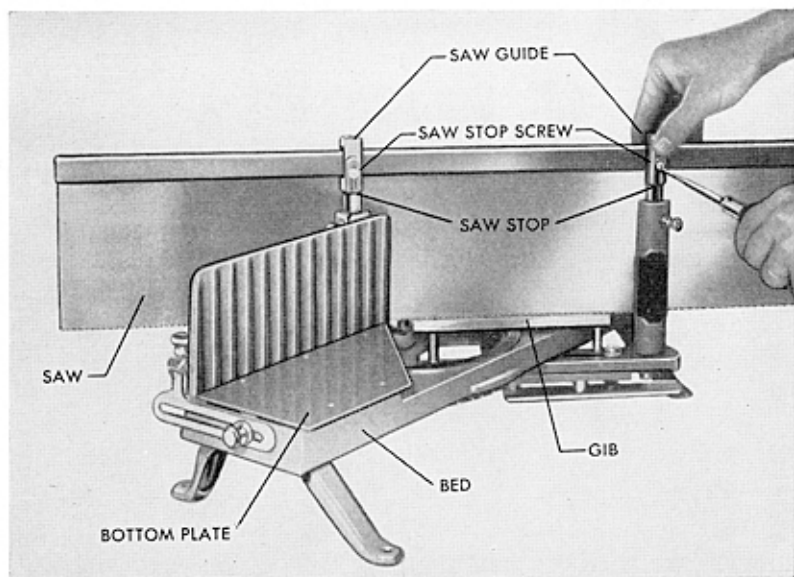

Figure 6

SAW STOPS

Insert the Saw carefully through the front and rear Saw Guides. Make sure the Saw Teeth do not contact any part of the Mitre Box. A Box purchased with Saw has the adjustable Saw Stops (located near the top of each Saw Guide) adjusted at the factory. The Saw Teeth should clear the bottom of the groove in the Gib with the proper clearance.

It is necessary for the owner to reset the adjustable Saw Stops on Box purchased without Saw. This is also required when Saw is resharpened. Resharpener diminishes the Saw height.

To adjust; loosen the Saw Stop Screws. Lower the Saw carefully as far as it will go. Set Saw Stops so that Saw clears bottom of groove in Gib, and is still below the surface of Bottom Plates (Fig. 6). Tighten Saw Stop Screws. With proper adjustment the Saw Teeth will not touch the bottom of the groove but will complete the Saw cut.

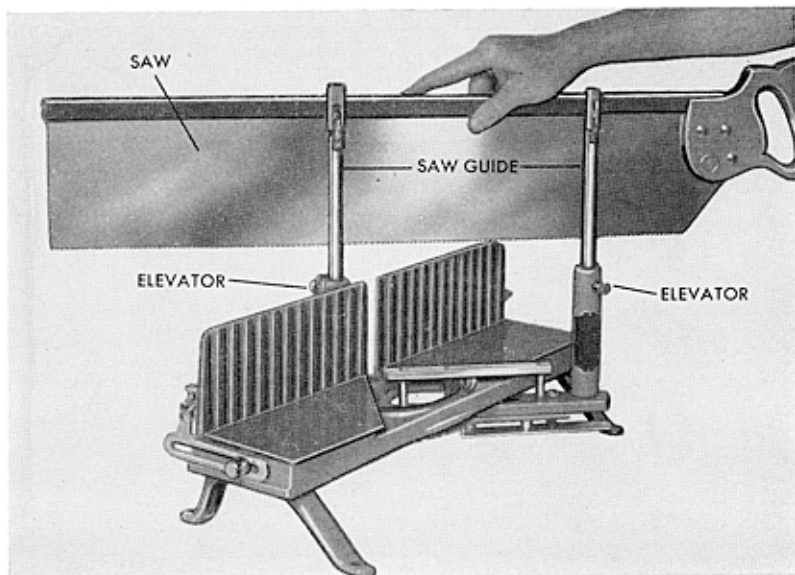

Figure 7

ELEVATORS

The Saw must be raised to allow work to be entered underneath it. It is held in the raised position by means of Elevators. These are located on the left side of each Saw Post.

To raise the Saw, grasp the Saw midway between the two Saw Guides and lift until both Elevators click (Fig 7.) The Saw will stay in this position. To drop the Saw, push down on the top of each Saw Guide with the palm of the hand. Be careful not to "slam" Saw on work.

The holding power of the Elevators can be adjusted to suit the operator. Merely turn the Knurled Nut on the Elevator provided for this purpose.

To remove the Saw Guide from the Post, pull out on the Knurled Elevator Nut, and remove Saw Guide.

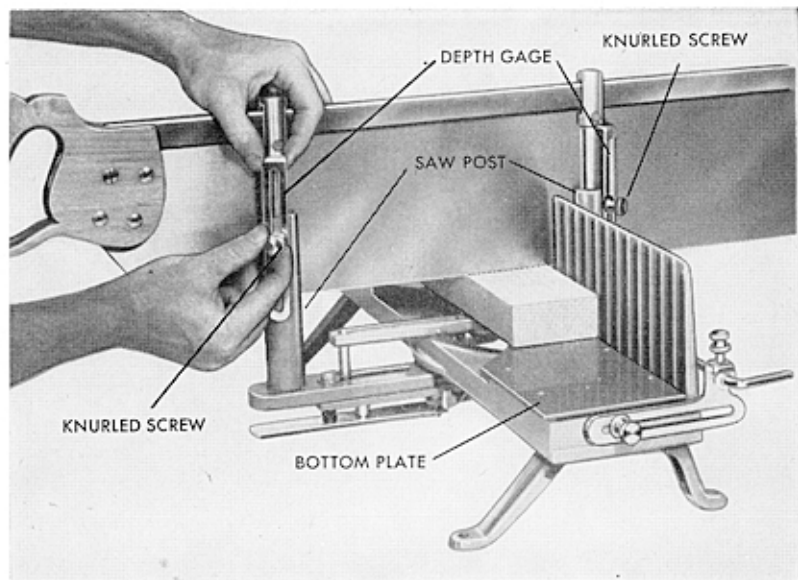

Figure 8

DEPTH GAGES

Depth Gages are mounted by means of Knurled Screws on the right side of each Saw Post. They are used to limit the depth of Saw cut. As assembled on the Mitre Box they are in the inoperative position.

The Saw must be in the raised position to adjust the Depth Gages. Insert a piece of wood equal in thickness to the height the Saw is to stop above the Bottom Plates. Gently lower the Saw on the wood. Raise Depth Gages up to the Shoulder of each Saw Guide, and tighten Knurled Screws (Fig. 8). Raise the Saw and remove wood. The Saw should now cut to the depth desired.

A slight readjustment of the Depth Gages is often necessary when sawing to extremely accurate depth. A trial cut on scrap wood will check accuracy of setting.

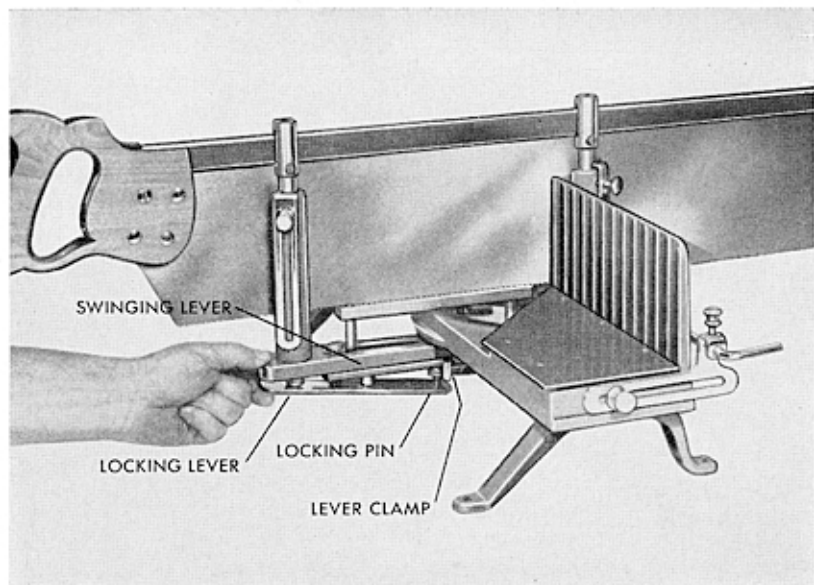

Figure 9

SWINGING LEVER

The Saw Guides carrying the Saw, and the Posts in which the Saw Guides operate, are all part of the Swinging Lever. From the Right Angle (or Square) this Lever swings horizontally 45° right (right Mitre) and 45° left (left Mitre). The Swinging Lever is attached to the Bed by means of a King Bolt.

The Lever Clamp must be loose to swing the Lever. This is accomplished by turning the Clamp clockwise as far as it will rotate.

To set the Saw at a desired Angle, pull the Locking Lever up with the forefinger while the thumb is on the Lever (Fig. 9). This disengages or prevents engagement of the Locking Pin (Index pin) with Notches in the Arc. The Swinging Lever will traverse freely only if Locking Pin is disengaged.

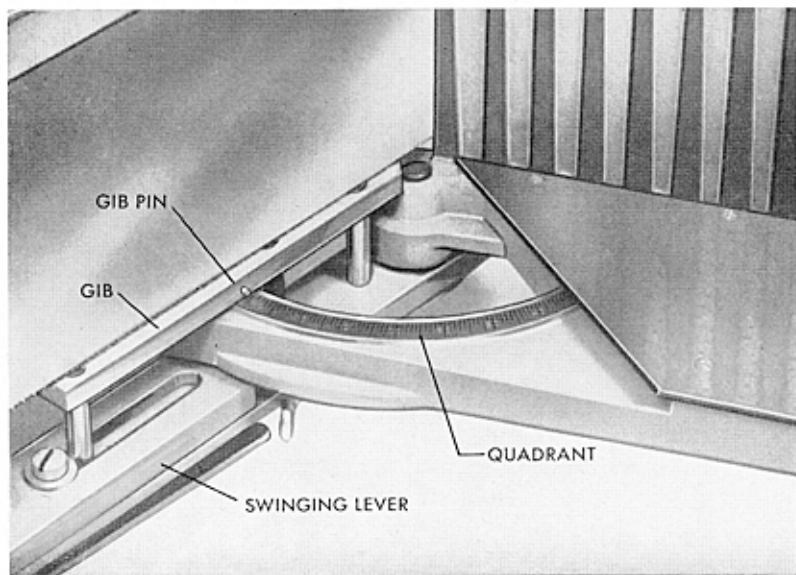

Figure 10

ARC

The Arc is the curved component of the Bed. The top is graduated in one degree divisions and is called the Quadrant. It covers a total of 90° (45° to the right, and 45° to the left from the Right Angle or Square). A small Pointer (Gib Pin) on the Gib points to the angle the Saw will cut (Fig. 10). There is no graduated Quadrant on the No. 1120 and No. 1124 Mitre Boxes.

The Swinging Lever slides on the bottom of the Arc. The Notches are for rapid setting of frequently used angles. Notches are at 0° (Right Angle) 9° , $22\frac{1}{2}^\circ$, 30° , and 45° (Mitre) right or left.

To use the Automatic Index, merely release the Locking Lever at a Notch. The Locking Pin will drop into the Notch. A gentle attempt to swing the Lever in either direction should be made to insure proper engagement between Locking Pin and Notch.

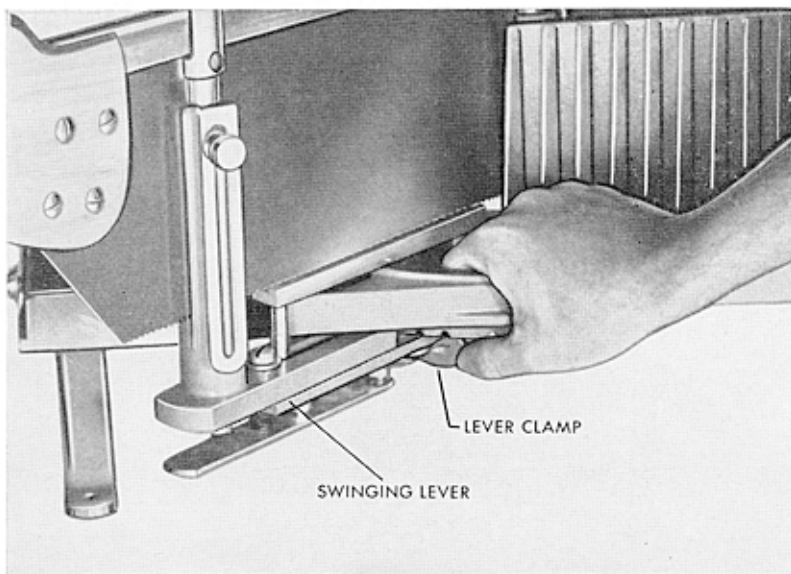

Figure 11

LEVER CLAMP

The Swinging Lever is locked to the Bed by means of a Lever Clamp. Locking is accomplished by rotating the Lever Clamp in a counterclockwise direction (Fig. 11).

The Swinging Lever should be locked to the Bed during all sawing operations. This also applies to quick angle adjustments where the Locking Pin is engaged with a Notch in the Arc. If Lever is not locked, the angle setting is apt to be changed by the work accidentally "bumping" into Saw or Post. BE SAFE, assure a true and accurate cut.

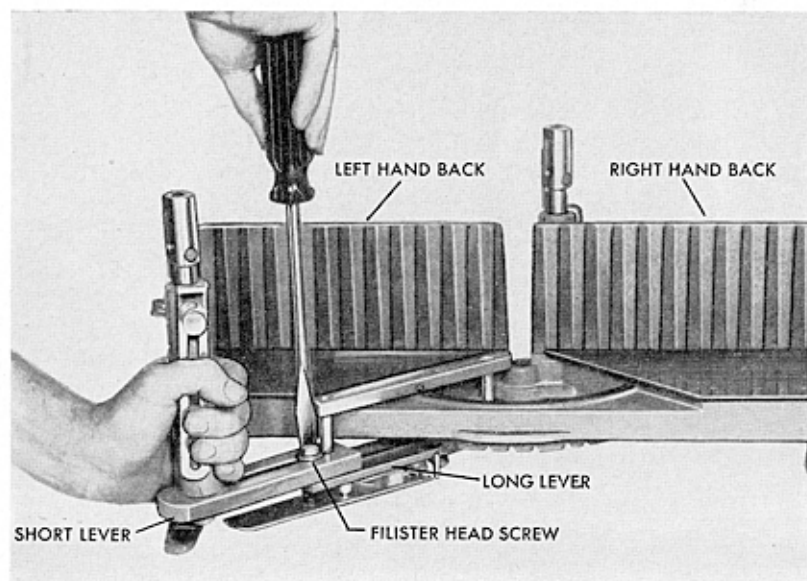

Figure 12

SLIDING LEVER

As received, the Mitre Box will cut a width of $8\frac{5}{16}$ inches at Right Angle and $5\frac{9}{16}$ inches at either Mitre. This is sufficient capacity for majority of work.

The maximum width of cut is $10\frac{1}{2}$ inches at Right Angle and $7\frac{1}{4}$ inches at either Mitre. To obtain this capacity, first remove the Saw. Loosen the Filister Head Screw which holds the Long and Short (Sliding) levers together. Extend the Short Lever to its maximum position and tighten Filister Head Screw (Fig. 12). The Mitre Box is ready for use upon replacement of Saw.

The Swinging Lever on the No. 1120 and No. 1124 Mitre Boxes is made in one piece without adjustment for changes of capacity.

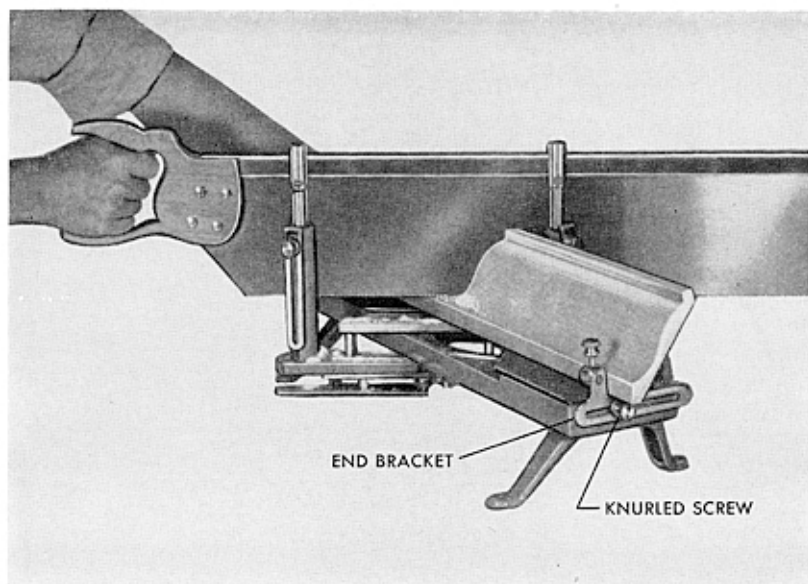

Figure 13

END BRACKETS

End Brackets which are held by Knurled Screws are provided on each end of the Bed. An Elongated Slot limits its travel. As received, they will not interfere with work placed on the Bed.

A Bent Lug on the top of the Bracket is used for a work stop. Additional forward adjustment is obtained by turning Bracket end for end (Fig. 13). Sawing crown moulding is one of the many useful operations employing the End Brackets in this position. The Bent Lugs provide a means for holding the moulding against the Bed Plates and Backs.

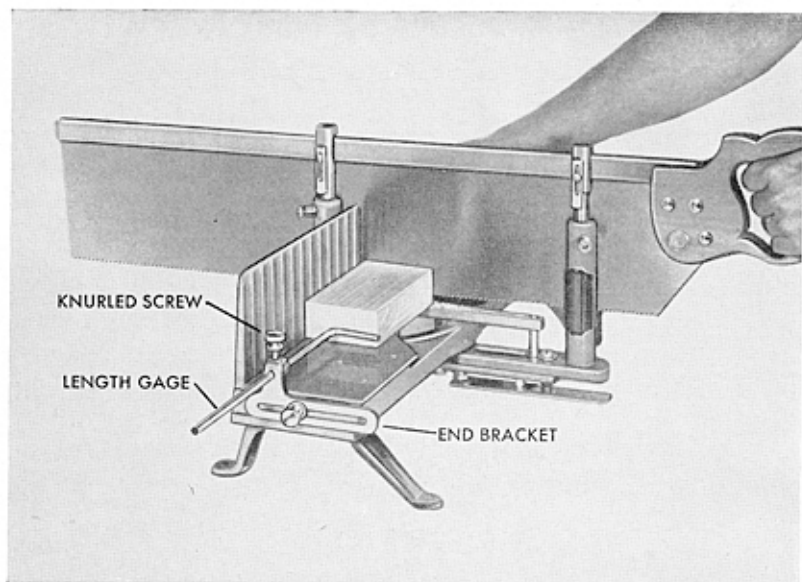

Figure 14

LENGTH GAGE

A reversible and adjustable Length Gage is provided on the right hand End Bracket. A Knurled Screw on the End Bracket holds this long bent rod.

The Length Gage is a stop for sawing a number of pieces to exactly the same length. By reversing or turning the Length Gage and shifting the End Bracket, very short or longer pieces can be cut. Fig. 14 shows a proper set-up for very short pieces on left side of Box.

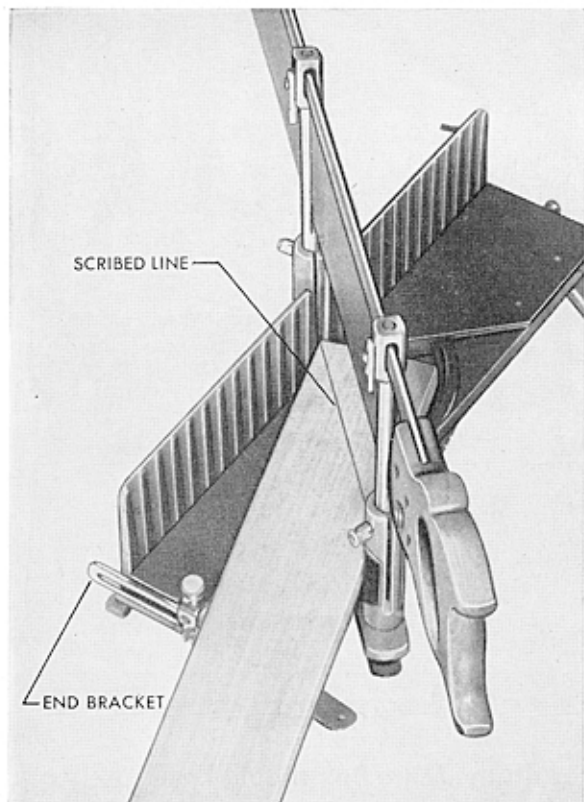

Figure 15

ACUTE ANGLES

Angles less than 45° can be cut with the Box. The Angle must first be scribed on the board. A Protractor is the most common device used. The Saw is swung to either left or right Mitre as required. The scribed line is placed directly beneath and in line with Saw Teeth. One End Bracket is adjusted so that the Bent Lug supports the board edge.

Figure 15 shows a typical acute angle set-up where corner of board is pivoted in gap between Backs. If necessary the board can be pivoted along the Bed Back or Bed Back Corner. In such cases use the Length Gage as an additional stop.

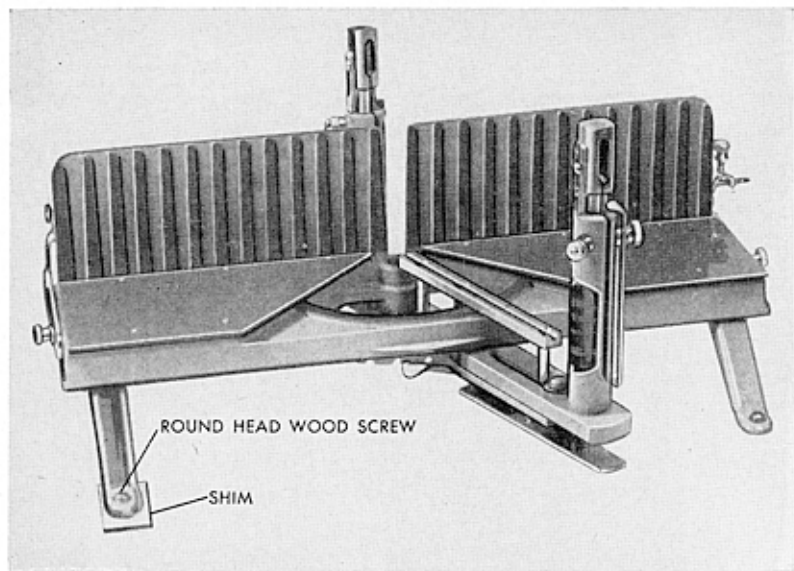

Figure 16

ANCHORAGE

For best results the Mitre Box should be securely anchored or fastened to the work bench. Screw holes for this purpose are provided in the Legs.

The bottom of the Legs are ground flat at the factory. The bench should also be flat so that all Legs rest solidly on it. Should the Box rock, place a "Shim" of the right thickness under the proper leg (Fig. 16). A box screwed down with a Leg needing a Shim will be warped. A warped Box will not cut accurately.

Do not fasten the Box to green lumber which may warp or shrink later.

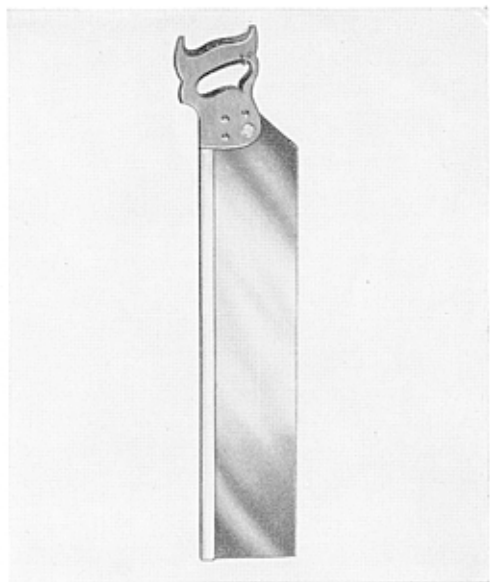

Figure 17

SAW

The Saw is the heart of the Mitre Box. The Saw purchased with Box is of high quality and is individually fitted to the Box. No two Saws will cut the same even though new.

A Mitre Box purchased without Saw may or may not cut accurately, consequently it cannot be guaranteed. For maximum accuracy, the Saw should be fitted at the factory.

The Saw should be kept sharp and only a qualified expert should do the refiling and resetting. Reset Saw Stops after refiling.

For smooth accurate cuts, operate the Saw with moderate steady strokes. Allow only the weight of the Saw to furnish the necessary feed. Pressure on the Saw tends to throw it out of alignment.

Keep Saw in prime condition. When not in use, remove it from Box and hang in safe place (Fig. 17). Saw should be oiled if not to be used for a prolonged period.



Fig. 18

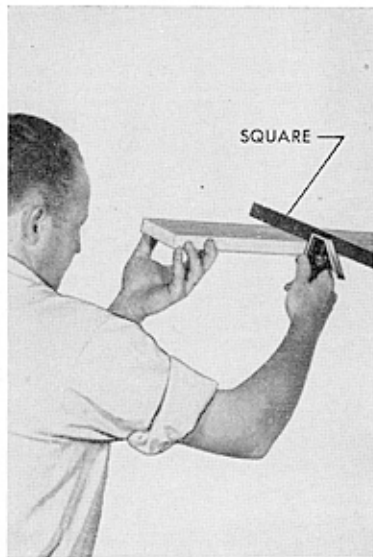

Fig. 19

LUMBER

This Mitre Box is a precision, hand operated Machine for cutting Angles in wood. It is intended for cutting clear straight lumber, free of knots and other defects.

Two adjacent sides of the stock to be cut **must** be absolutely straight and flat (Fig. 18); their included angle **exactly** square or 90° (Fig 19). These two surfaces **must** contact both Backs and Bed Plates of the Box. Hold stock securely while cut is made. Accurate cuts are made only on accurate stock. **DO NOT EXPECT ACCURATE CUTS ON WARPED OR CROOKED LUMBER.**

The same stock Edge must be against the Backs while all cuts are made. **Never** turn the work over, or end for end, but reverse the Angle of the Saw when necessary.

All the above conditions must be met, otherwise the result will be an inaccurate cut. Sawing through knots may sometimes be necessary, and this may cause the Saw to spring or bend.

SHOP KEEPING

1. If Lever binds or sticks, add few drops of oil (wipe off excess) between Swinging Lever and Mitre Box Bed at King Bolt junction and bottom of Arc.
2. Never oil Saw Guides or Saw during use. Sawdust will cause them to stick and bind.
3. Prevent damage to Saw by hanging it in a safe place when not using.
4. Oil Saw Guides, Saw and Machined Surfaces on Bed only when Box is not to be used for a prolonged period.
5. Make sure Swinging Lever is locked to Bed by means of Lever Clamp before making cut. This is to insure against accidentally changing angle.
6. Keep Saw sharp. Refiling and resetting should only be done by a qualified expert.
7. Never apply pressure to Saw. Allow only weight of Saw to furnish necessary feed.
8. Two adjacent surfaces of stock must be straight and flat and their included angle exactly square or 90° . They must contact both Backs and Bottom Plates.
9. Stock must be held firmly against Backs and Bottom Plates while sawing.
10. Same edge of stock must be against and contact Backs of Bed while all cuts are made. Never turn work over, or end for end, but reverse the angle of Saw when necessary.
11. Do not expect accurate cuts on warped or crooked lumber. Accurate cuts are made only on accurate lumber.
12. Never file Index Notches on Bottom of Arc or Locking Pin which engages Notches.
13. Never attempt to reset Locking Pin Bushing. It has been properly set at the Factory.

HOW TO ORDER REPAIR PARTS

All parts shown on the following pages may be ordered from your MILLERS FALLS Hardware Dealer or by Mail Order from the factory.

WHEN ORDERING REPAIR PARTS ALWAYS: —

1. Give Model Number of Mitre Box.
2. Number of Part on List.
3. Name of Part on List.
4. How many each part desired.
5. Enclose Money Order or Check for Parts.
6. Your name and address (please type or print clearly).

MILLERS FALLS COMPANY
GREENFIELD, MASS., U. S. A.

PARTS LIST FOR MILLERS FALLS "LANGDON ACME" MITRE BOXES

With Saw

- No. 72C — 24 x 4 Saw
 No. 73C — 26 x 4 Saw
 No. 74C — 28 x 5 Saw
 No. 75C — 30 x 5 Saw

Without Saw

- No. 1071C — 4 Inch
 No. 1074C — 5 Inch

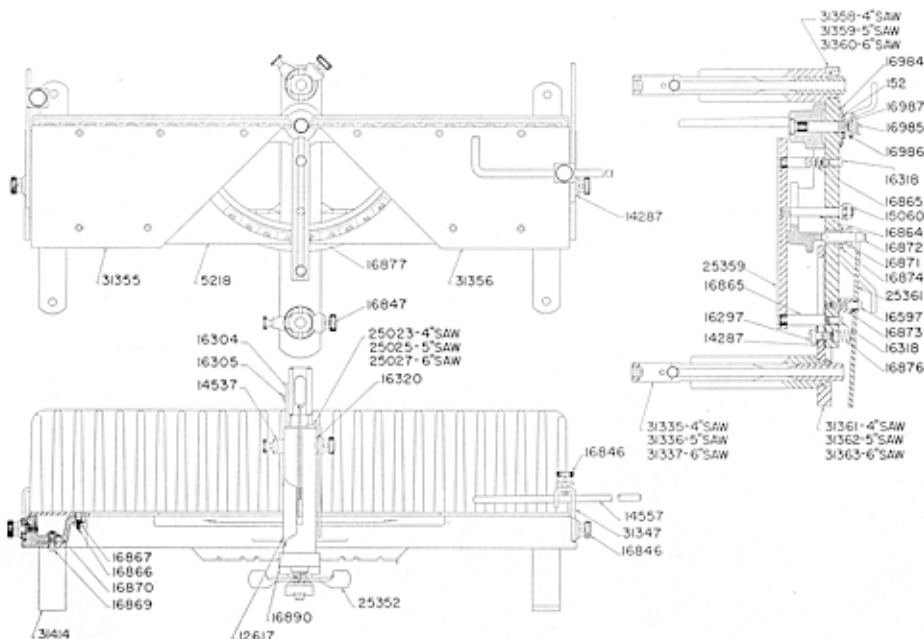

No.	Part	Price each	No.	Part	Price each
152	King Bolt Knurled Washer	\$.12	16876	Locking Lever Spring	.12
5218	Bed	10.50	16877	Gib Indicator Pin	.12
12617	Name Plate Screw (2)	.12	16890	Name Plate	.18
14287	Washer (3)	.12	16984	King Bolt Spring Washer	.12
14537	Elevator Put-up (2)	.42	16985	King Bolt	.36
14557	Length Gauge	.30	16986	King Bolt Castellated Nut	.12
15060	Hex Nut	.12	16987	King Bolt Cotter Pin	.12
16297	Fillister Head Screw	.12	25023	Depth Gauge (4" Saw) (2)	.18
16304	Saw Stop (2)	.12	25025	Depth Gauge (5" Saw) (2)	.18
16305	Saw Stop Screw (2)	.12	25352	Lever Clamp	.12
16318	Gib Plug Screw (2)	.12	25359	Gib	.84
16320	Depth Gauge Bent Washer (2)	.12	25361	Locking Lever	.18
16597	Round Head Screw	.18	31335	Saw Guide Put-up (4" Saw) (2)	2.76
16846	End Bracket Screw (4)	.18	31336	Saw Guide, complete (5" Saw) (2)	2.76
16847	Depth Gauge Screw (2)	.18	31347	End Bracket (2)	.48
16864	Binding Screw	.18	31355	Bottom Plate—left hand	1.02
16865	Gib Plug (2)	.12	31356	Bottom Plate—right hand	1.02
16866	Bottom Plate Screw (10)	.12	31358	Long Lever Put-up (4" Saw)	4.20
16867	Bottom Plate Nut (10)	.12	31359	Long Lever Put-up (5" Saw)	4.20
16869	Leg Screw (4)	.12	31361	Short Lever Put-up (4" Saw)	3.36
16870	Leg Nut (4)	.12	31362	Short Lever Put-up (5" Saw)	3.36
16871	Locking Pin Bushing	.36	31414	Leg (2)	.36
16872	Locking Pin	.18			
16873	Locking Lever Bushing	.12			
16874	Locking Pin Bushing Check Nut	.12			

Prices subject to change without notice

PARTS LIST FOR

MILLERS FALLS "LANGDON" MITRE BOXES

With Saw
No. 1124 - 24 x 4 Saw

Without Saw
No. 1120

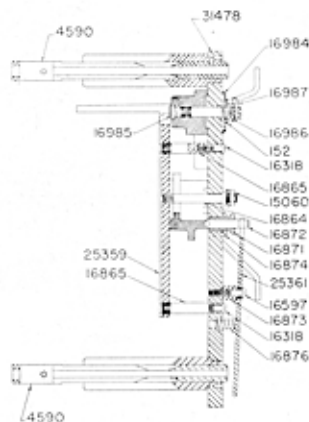
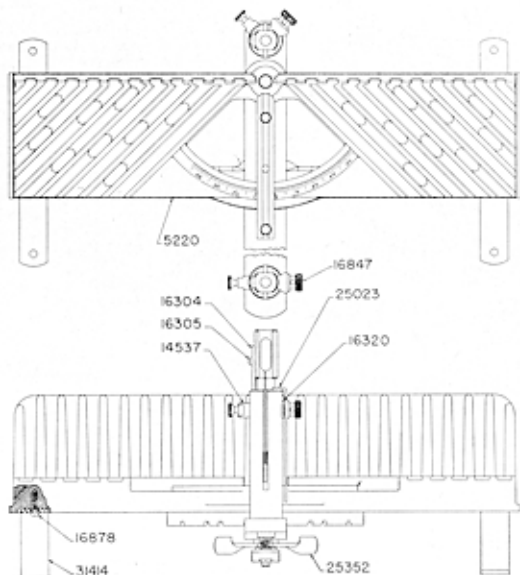

Part No.	Description
152	Saw (24 x 4)
16847	King Bolt Washer
4590	Saw Guide (2)
5220	Bed
14537	Elevator Put-up (2)
16304	Saw Stop (2)
16305	Saw Stop Screw (2)
16318	Gib Plug Screw (2)
16320	Depth Gauge Bent Washer (2)
16597	Round Head Screw

Part No.	Description
16847	Depth Gauge Screw (2)
16864	Binding Screw
16865	Gib Plug (2)
16871	Locking Pin Bushing
16872	Locking Pin
16873	Locking Lever Bushing
16874	Locking Pin Bushing Check Nut
16876	Locking Lever Spring
16878	Leg Screw (4)

Part No.	Description
16984	Spring Washer
16985	King Bolt
16986	Castellated Nut
16987	Cotter Pin
25023	Depth Gauge (2)
25352	Lever Clamp
25359	Gib
25361	Locking Lever
31358	Long Lever Put-up
31414	Legs (2)
31478	Swinging Lever

PARTS LIST FOR MILLERS FALLS "ALL STEEL" MITRE BOXES

With Saw

Without Saw

- No. 1244C — 24 x 4 Saw
- No. 1264C — 24 x 4 Saw
- No. 1285C — 28 x 5 Saw
- No. 1305C — 30 x 5 Saw
- No. 1306C — 30 x 6 Saw

- No. 1002C — 4 Inch
- No. 1003C — 5 Inch
- No. 1004C — 6 Inch

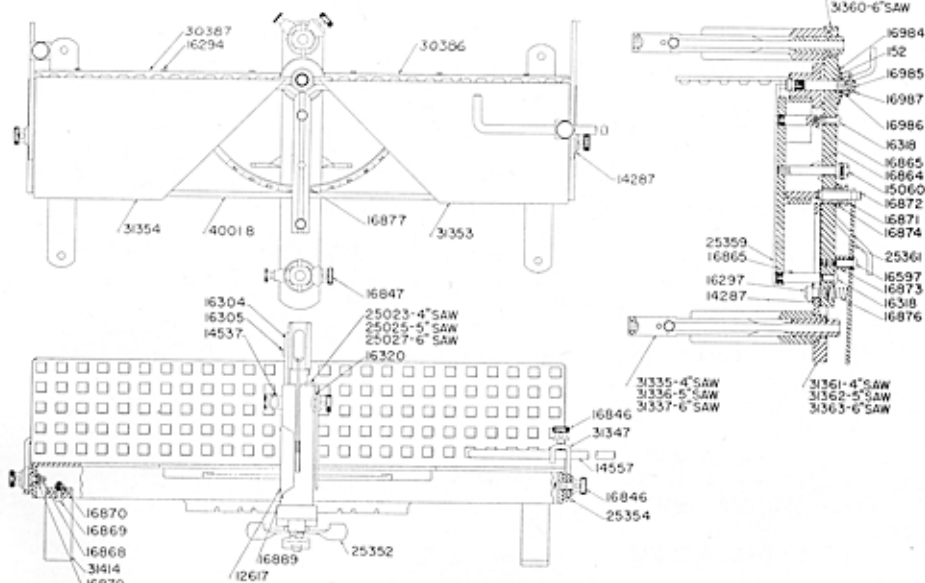

No.	Part	Price each	No.	Part	Price each
152	King Bolt Knurled Washer	\$.12	16985	King Bolt	.36
12617	Name Plate Screw (2)	.12	16986	King Bolt Castellated Nut	.12
14287	Washer (3)	.12	16987	King Bolt Cortor Pin	.12
14537	Elevator Put-up (2)	.42	25023	Depth Gauge (4" Saw) (2)	.18
14557	Length Gauge	.30	25025	Depth Gauge (5" Saw) (2)	.18
15060	Hex Nut	.12	25027	Depth Gauge (6" Saw) (2)	.18
16294	Back Screw (6)	.12	25352	Lever Clamp	.12
16297	Fillister Head Screw	.12	25354	End Plate (2)	.18
16304	Saw Stop (2)	.12	25359	Gib	.84
16305	Saw Stop Screw (2)	.12	25361	Locking Lever	.18
16318	Gib Plug Screw (2)	.12	30386	Back — right hand	1.38
16320	Depth Gauge Bent Washer (2)	.12	30387	Back — left hand	1.38
16597	Round Head Screw	.12	31335	Saw Guide Put-up (4" Saw) (2)	2.76
16846	End Bracket Screw (4)	.18	31336	Saw Guide, complete (5" Saw) (2)	2.76
16847	Depth Gauge Screw (2)	.18	31337	Saw Guide, complete (6" Saw) (2)	2.76
16864	Binding Screw	.18	31347	End Bracket (2)	.48
16865	Gib Plug (2)	.12	31353	Bottom Plate — right hand	.84
16868	End Plate Screw (4)	.12	31354	Bottom Plate — left hand	.84
16870	Leg Nut (8)	.12	31358	Long Lever Put-up (4" Saw)	4.20
16871	Locking Pin Bushing	.36	31359	Long Lever Put-up (5" Saw)	4.20
16872	Locking Pin	.18	31360	Long Lever Put-up (6" Saw)	4.20
16873	Locking Lever Bushing	.12	31361	Short Lever Put-up (4" Saw)	3.36
16874	Locking Pin Bushing Check Nut	.12	31362	Short Lever Put-up (5" Saw)	3.36
16876	Locking Lever Spring	.12	31363	Short Lever Put-up (6" Saw)	3.36
16877	Gib Indicator Pin	.12	31414	Leg (2)	.36
16889	Name Plate	.18	40018	Bed Put-up	12.60
16984	King Bolt Spring Washer	.12			

Prices subject to change without notice

CONTENTS

	PAGE
GUARANTEE	Inside of Cover
CLAIMS	Inside of Cover
"LANGDON ACME" MITRE BOX	1
"LANGDON" MITRE BOX	2
"ALL STEEL" MITRE BOX	3
REMOVAL	4
SAW GUIDES	5
SAW STOPS	6
ELEVATORS	7
DEPTH GAGES	8
SWINGING LEVER	9
ARC	10
LEVER CLAMP	11
SLIDING LEVER	12
END BRACKETS	13
LENGTH GAGE	14
ACUTE ANGLES	15
ANCHORAGE	16
SAW	17
LUMBER	18
SHOP KEEPING	19
HOW TO ORDER REPAIR PARTS	20
PARTS LIST "LANGDON ACME"	21
PARTS LIST "LANGDON"	22
PARTS LIST "ALL STEEL"	23

OTHER TOOLS MADE BY MILLERS FALLS

Millers Falls Company has been a leading producer of the finest hand and power tools for home and industry since 1868. Our tools are famous all over the world for their outstanding quality and appearance.

The extensive line of Millers Falls products includes:

- Home and Professional Hand Tools
- Machinists' Precision Tools
- "Dyno-Mite" Electric Tools
- Industrial Electric Tools
- Hand and Power Hack Saw Blades
- Hole Saws and Band Saw Blades

Illustrated below are some examples of the Millers Falls line of carpenters' tools — ideal companions for your mitre box.

PLANES



POWER BITS



BIT BRACES



LEVELS



KEYHOLE SAWS



SCREWDRIVERS



SPIRAL SCREWDRIVERS



HAND DRILLS



CARPENTER'S SQUARES



HACK SAW FRAMES



#43 COPING SAW

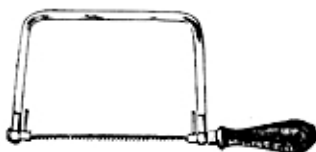

#39 WOOD SCRAPER



#185 AUTOMATIC DRILL

